

Fled MKIII
Keel x 2
1u = 9 5/16"
1/4" seam
allowance added

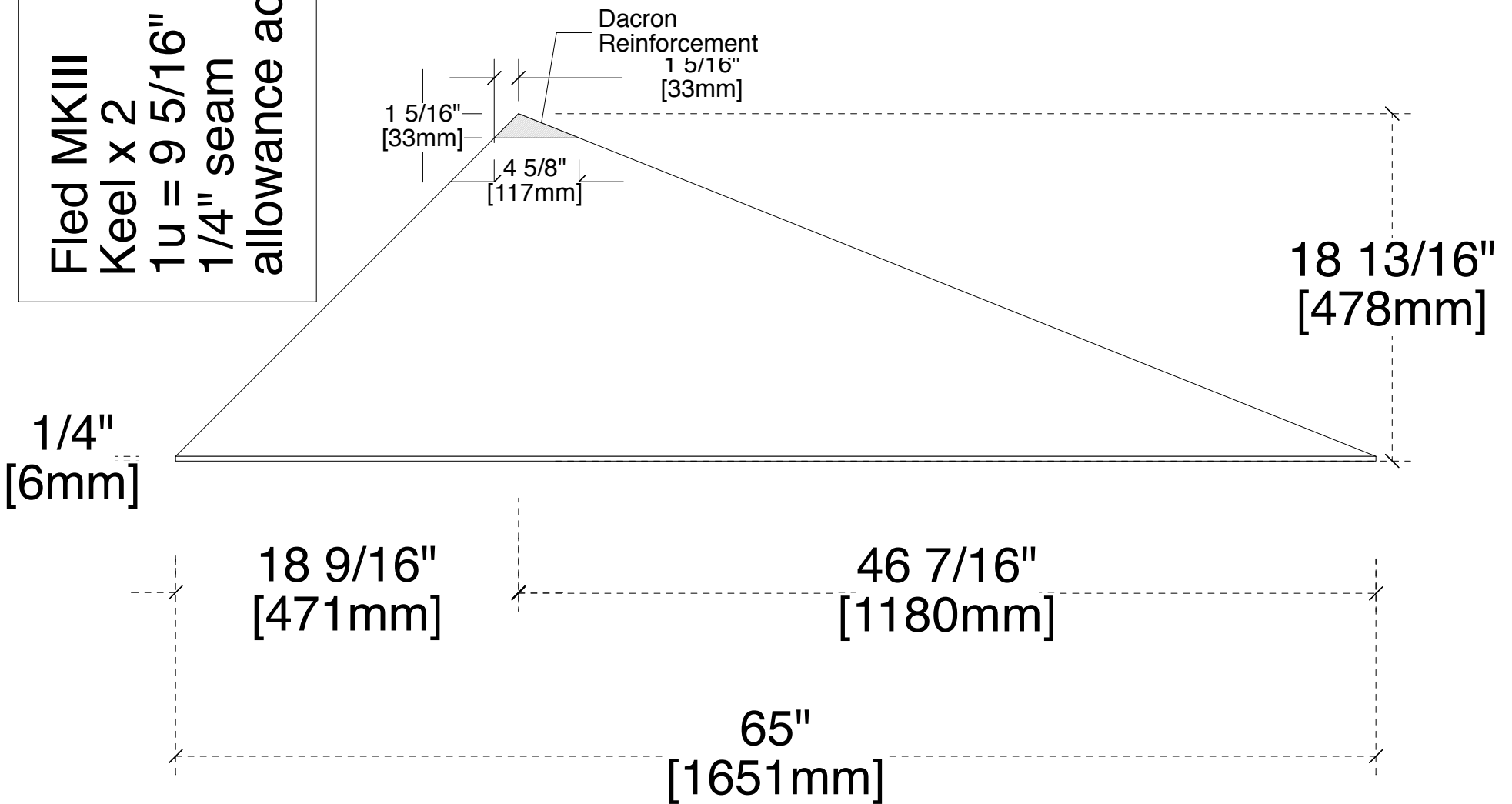

Fled MKIII
 Wing x 2
 1u = 9 5/16"
 1/4" Seam
 allowance added

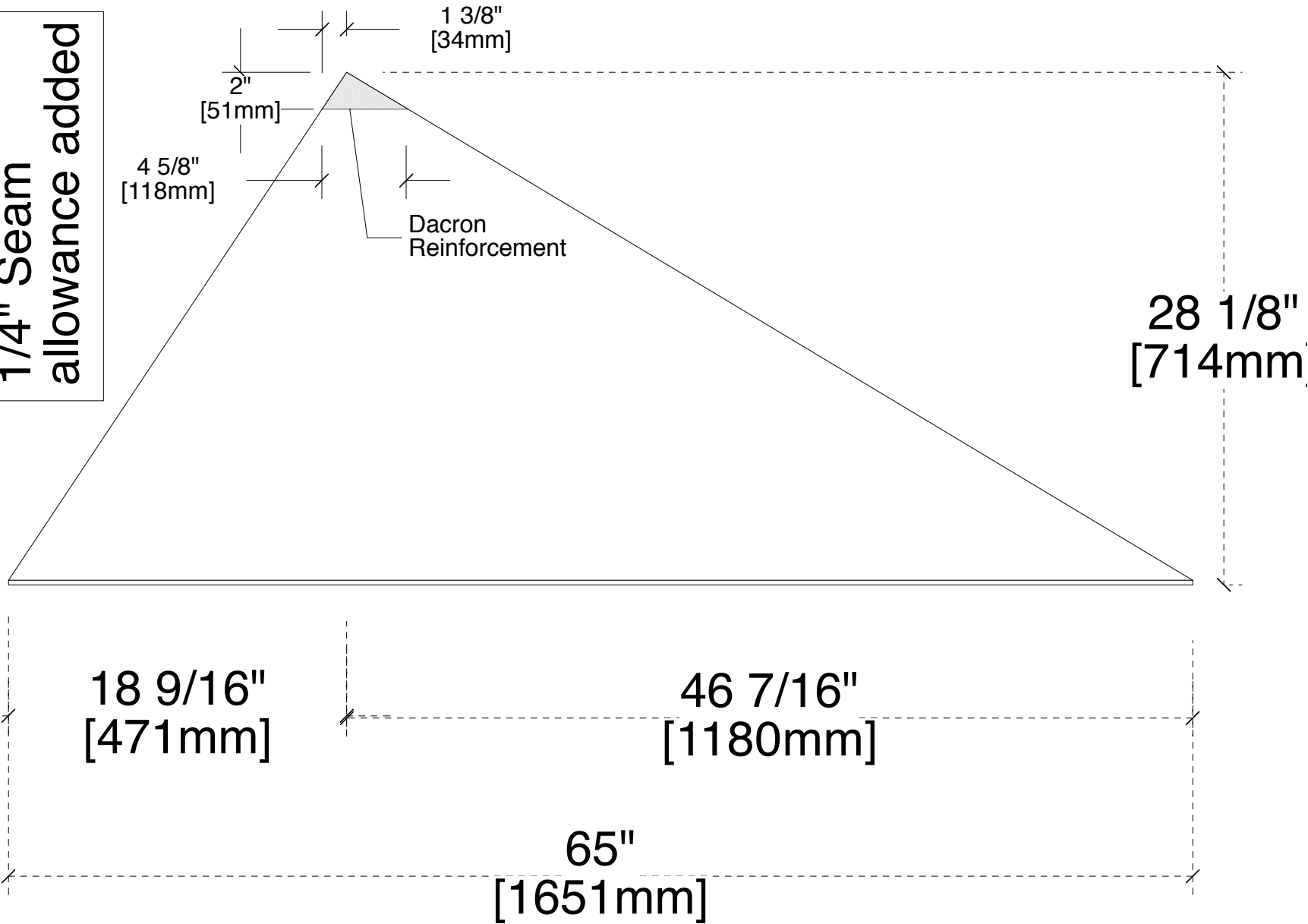

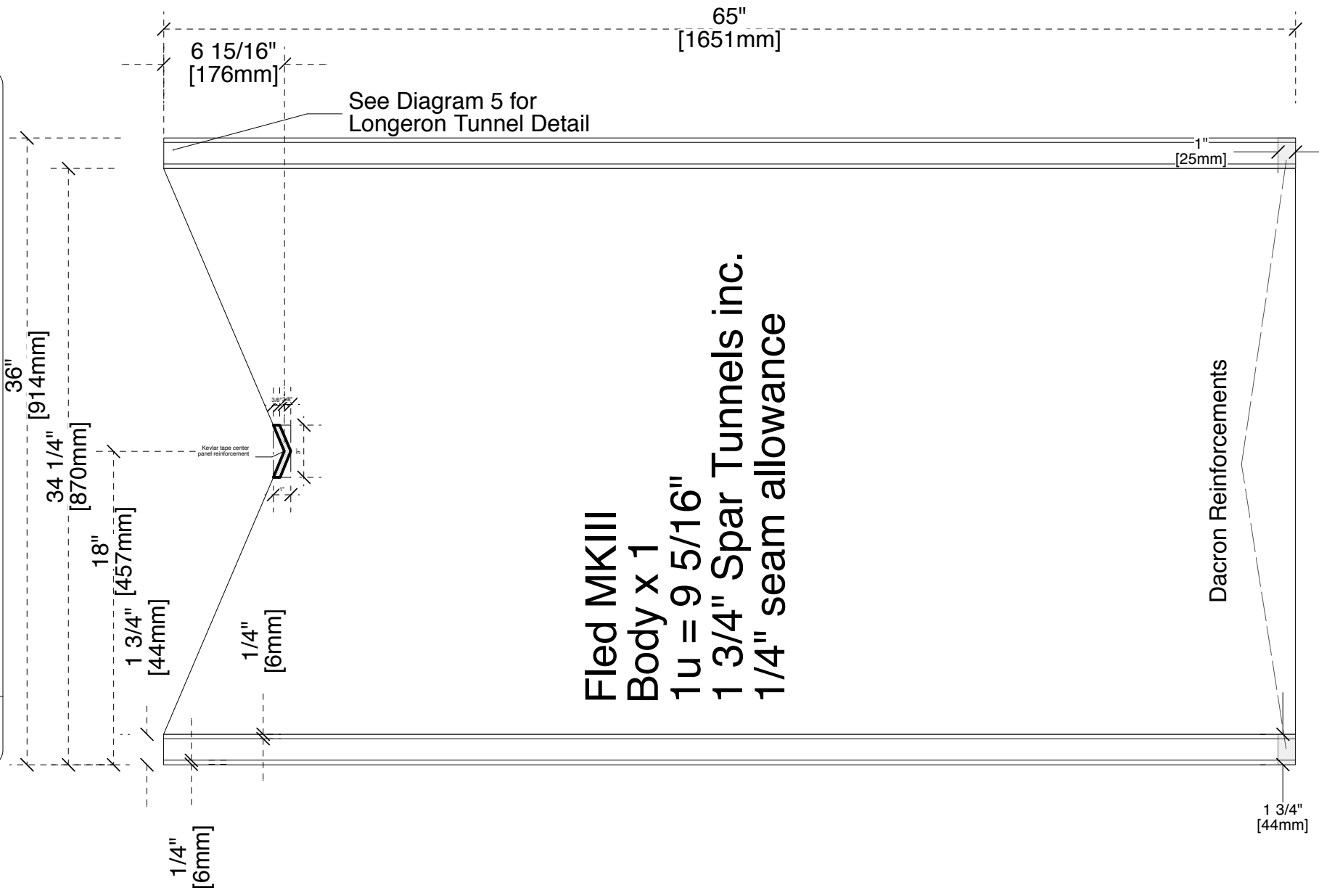

Fled MKIII
Body x 1
1u = 9 5/16"
1 3/4" Spar Tunnels inc.
1/4" seam allowance

Fled MKIII
Drogue Panel x 4
1u = 9 5/16"
1/4" seam allowance added

